



SERIES TT-E

Rango de torque 106 a 11.500 Nm

-  EJE CUADRADO
-  ALLEN DIRECTO
-  STACK SOCKET
-  METABO LION18
-  REGISTRO DE DATOS
-  TORQUE+ANGULO

El TT-E es una herramienta eléctrica de torque avanzado, ideal para aplicaciones industriales que requieren alta precisión y eficiencia. Operando a 230V, este equipo ofrece un rendimiento superior con controles electrónicos intuitivos que garantizan ajustes exactos de torque. Su diseño ergonómico facilita el manejo en espacios reducidos, asegurando la seguridad y comodidad del usuario. Además, su construcción robusta asegura durabilidad y fiabilidad en entornos de trabajo exigentes. Perfecto para tareas de torqueado de alta demanda.

INFORMACION TECNICA

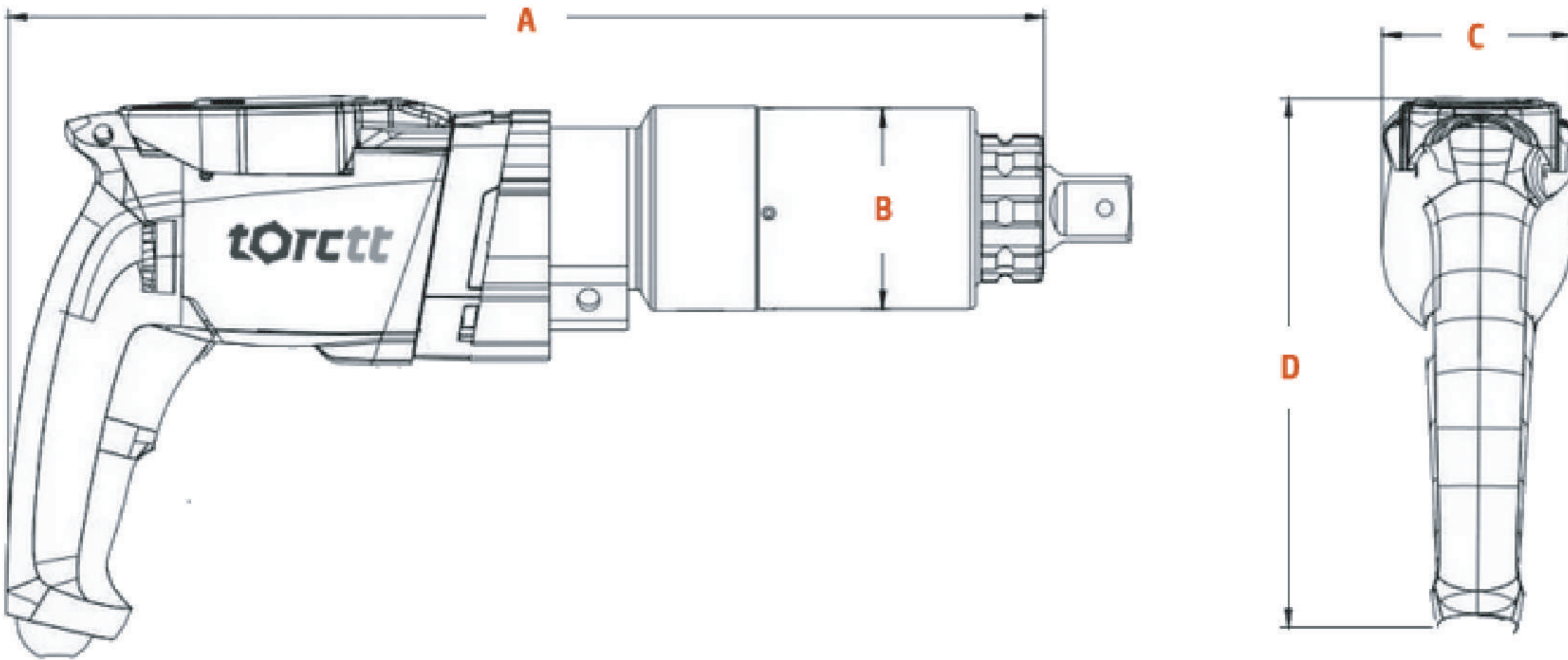

MODELO	SQD (pulgadas)	TORQUE				VELOCIDAD (rpm)	PESO (kg)	A (mm)	B (mm)	C (mm)	D (mm)
		MIN Nm	MAX Nm	MIN ft.lb	MAX ft.lb						
TT-E700	3/4"	100	700	73	516	20	4	300	66	67	210
TT-E1400	1	200	1.200	147	885	11	6.3	375	77	67	210
TT-E2200	1	300	2.200	221	1.622	7	7	375	77	67	210
TT-E4000	1	600	3.700	442	2.730	4	9.5	425	92	67	210
TT-E5000	1 1/2	800	4.800	590	3.540	3.1	12	435	102	67	210
TT-E6000	1 1/2	900	5.700	663	4.204	3	12.5	435	110	67	210
TT-E8000	1 1/2	1.200	7.500	885	5.532	2	13	435	110	67	210
TT-E10000	1 1/2	1.500	9.500	1.106	7.007	1.5	18	455	116	67	210
TT-E12000	2"	1.800	11.500	1.327	8.482	1	20	475	127	67	210

ACCESORIOS

